



## Surgical Technique

Conventional instrumentation



# Table of contents

## UNI SCORE - Unicompartmental Knee System

Introduction .....	4
Implant UNI SCORE .....	5
Overview of the surgical technique .....	10
Pre-operative planning .....	13
Etape 1 : Extra-medullary guide .....	14
Etape 2 : Tibial resections .....	18
Etape 3 : Extension and flexion gaps .....	19
Etape 4 : Femoral resections .....	20
Etape 5 : Trial implants and joint testing .....	22
Etape 6 : Femoral and tibial preparation .....	22
Etape 7 : Cementless tibial tray for fixed bearing insert .....	23
Etape 8 : All-polyethylene tibial component cemented .....	25
Etape 9 : Femoral component .....	26
Appendix A .....	27
Extraction .....	29
Instrumentation .....	30

---

# Introduction

- This surgical technique is related to the UNI SCORE Conventional/navigated instrument set which allows the UNI SCORE Unicompartmental Knee System to be fitted.
- The instrumentation can be used:
  - in conventional (mechanical) version
  - in Computer-Assisted Surgery version (by adding the Navigation Set for UNI SCORE)
  - with the i.M.A.G.E. Patient Specific Instrumentation



# Implant UNI SCORE

• The UNI SCORE Unicompartmental Knee System consists of:

- a cemented femoral component compatible with cementless tibial tray for fixed bearing insert with peg and optional fixation screw or All-poly Tibial Component Cemented

or

- a cementless femoral component compatible with cementless tibial tray for fixed bearing insert with peg and optional fixation screw.

• Cementless tibial tray for fixed bearing insert with peg and optional fixation screw



• All-poly Tibial Component Cemented

# Implant UNI SCORE

## Femoral component

Primary stability ensured by two parallel pegs forming a 65° angle with the distal cut (prevents implant expulsion)

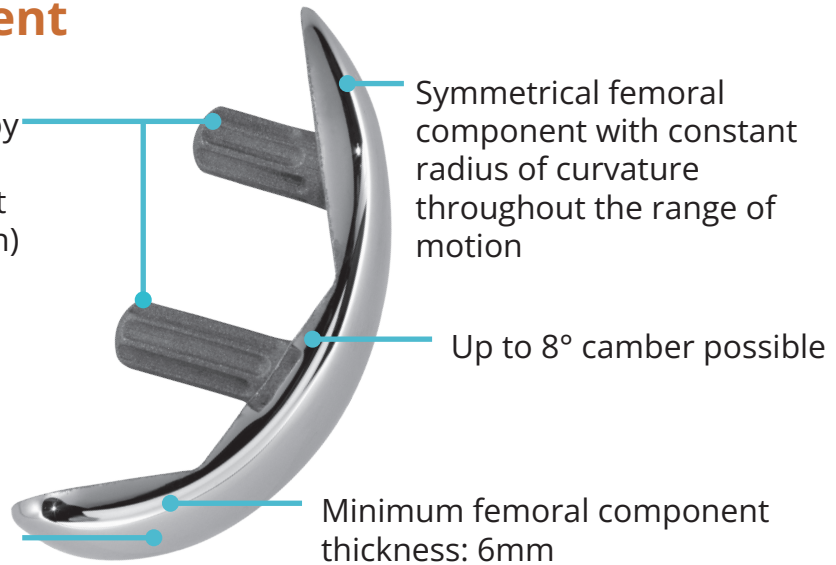

Made of Cobalt Chromium alloy (CoCrMo) for the cemented version and associated with double coating (80 µm plasma-sprayed titanium and 80 µm hydroxyapatite (HA) for cementless version).

## Tibial components

### Tibial tray for fixed bearing insert :

Cementless asymmetrical tibial tray for fixed bearing insert (RM/LL and LM/RL (80 µm plasma-sprayed titanium + 80 µm HA))  
Material: Cobalt Chromium alloy (CoCrMo)

Ultra High Molecular Weight Polyethylene (UHMWPE) insert

All surfaces that are in contact with the insert have a polished finish  
Insert locked using double snap-in mechanism

Primary stability of tibial tray achieved through sagittal fin

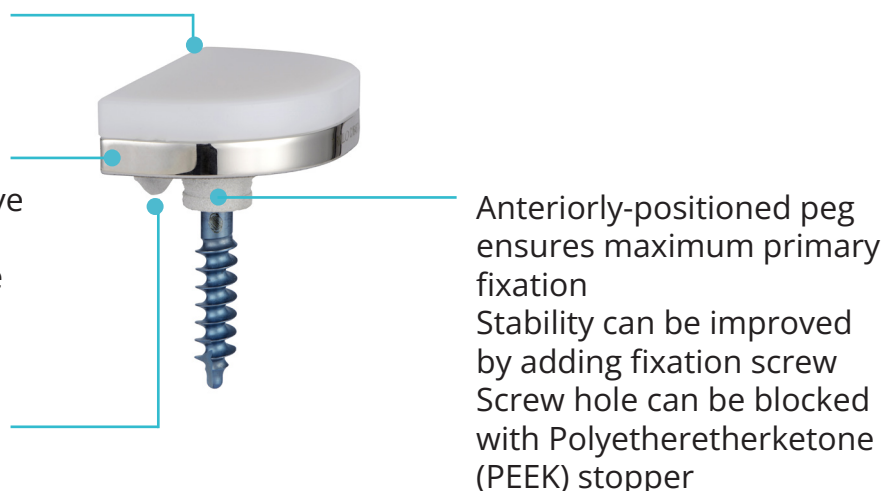

# Implant UNI SCORE

## Tibial component

### All-poly Tibial Component Cemented

The all-polyethylene tibial component cemented is symmetrical  
Flat bearing surface

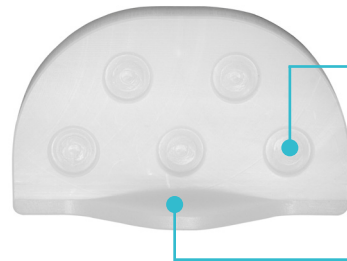

Underside of implant has 5 hollowed-out areas or cement, which ensures primary stability along with sagittal fin

## Product line

- Femoral components :
  - Cemented: 7 sizes (from 1 to 7)
  - Cementless : 7 sizes (from 1 à 7)

### Tibial components :

Implants	Tibial tray	Inserts
UNI SCORE Tibial tray for fixed insert Cementless	7 sizes (1 to 7) RM/LL 7 sizes (1 to 7) LM/RL	7 sizes (1 to 7) 4 thicknesses (9 to 12mm)
UNI SCORE All-polyethylene Tibial Component Cemented		7 sizes (1 to 7) 5 thicknesses (8 to 12 mm)

# Implant UNI SCORE

## Product line

▸ All implants available in 1 mm increments :

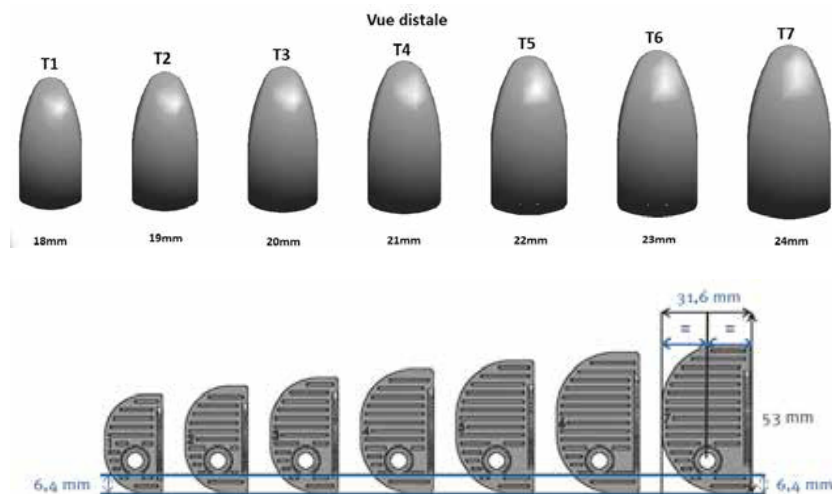

	S1	S2	S3	S4	S5	S6	S7
Distance M/L (mm)	20.8	22.6	24.4	26.2	28	29.8	31.6
Distance A/P (mm)	35	38	41	44	47	50	53

▸ Peg dimensions (same for all sizes) :

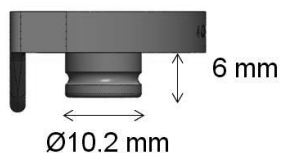

# Implant UNI SCORE

## Component compatibility

### UNI SCORE femoral components and tibial trays :

- The UNI SCORE All-poly Tibial Component Cemented is compatible with all sizes of the UNI SCORE cemented femoral component.
- The UNI SCORE tibial trays for fixed bearing insert is compatible with all sizes of the UNI SCORE femoral component.

### UNI SCORE femoral components and tibial inserts:

- The UNI SCORE tibial fixed bearing insert is compatible with all sizes of the UNI SCORE femoral component.

### UNI SCORE tibial tray and tibial inserts :

- The UNI SCORE tibial insert and optional fixation screw  $\varnothing$  6.5 mm must be used only with the UNI SCORE tibial tray for fixed bearing insert cementless Right Medial/Left Lateral (RM/LL) and Left Medial/Right Lateral (LM/RL).

- The fixed bearing insert must be exactly the same size as the tibial tray for fixed bearing insert cementless.

- It is compulsory to use a UNI SCORE tibial tray for fixed bearing insert when a fixation screw is associated with it. Whether used with or without a fixation screw, the peg of the tibial tray is filled by a blanking plug (supplied in the tibial tray packaging) by the surgeon before implantation. Once inserted in the peg, the blanking plug is not in contact with the polyethylene insert or the patient's bone, it is used to limit the release of particles.

---

# Surgical Technique Overview

1

Placing the Extra-medullary guide



2

Placing the joint line gauge and adjustments



3

Fixing the resection guide and performing the cuts



4

Verification of FLEXION gap

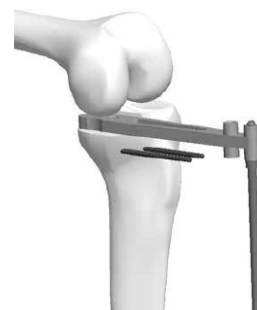

# Surgical Technique Overview

5

Verification of  
EXTENSION gap



6

Distal resection guide  
put into place and  
cut made

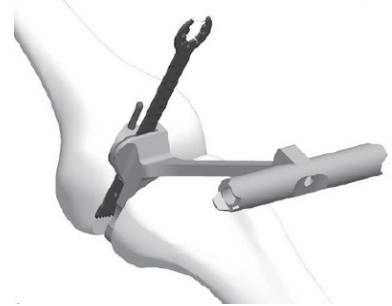

7

Placing the posterior and  
chanfer femoral resection  
guide and performing the  
cuts



8

Placing the trial  
implants and joint  
tested



---

# Surgical Technique Overview

9

**2 femoral pegs  
preparation**



10

**Sagittal fin  
preparation**



11

**Cementless tibial tray to  
fixed bearing insert : Peg  
preparation**



# Pre-operative planning

## Radiological assessment:

- Long-leg view with patient standing on single leg,
- A/P Schuss view (size and depth of depression on tibial plateau),
- A/P varus/valgus stress views (shows if deformity can be reduced),
- A/P standing view,
- Lateral standing view (reveals ACL status),
- 30° axial view (confirms condition of patellofemoral joint).

## Radiographs and templates are used to evaluate the following:

- Tibial epiphyseal varus,
- Tibial slope,
- Height of tibial cut,
- Estimate tibiofemoral mechanical axis once Unicompartimental Knee Arthroplasty (UKA) is put into place,
- Identify anterior osteophytes that need to be resected.

### NOTE

**The provided templates have a 1:1 scale.  
Make sure the template scale matches the  
X-ray scale.**

### REMINDER

**This surgical technique describes how to use the  
instrumentation properly.  
The surgeon is fully responsible for choosing the  
surgical approach and technique.**

# 1 Extra-medullary tibial guide

## Preparation :

- After the joint has been opened, the tibial plateau must be well exposed.
- Flex the knee 90°.
- Remove any medial osteophytes.

See page 27 for assembly on back table.

Assemble the Extramedullary slide bar with the Unicompartmental tibial guide (right or left) and the Extramedullary alignment column Ø8 mm

Assemble the Malleolar clamp on the alignment column.

Adjust the varus/valgus (yellow knob) according to the pre-operative plan. The varus/valgus angle is set relative to the Extramedullary alignment frame.

Set the resection height to 8 mm (green knob). This setting can be readjusted later on as needed.

Loosen the slope locking screw (blue knob), mediolateral adjustment screw (brown knob), rotation adjustment screw (pink knob), and the height and rotation locking screws.

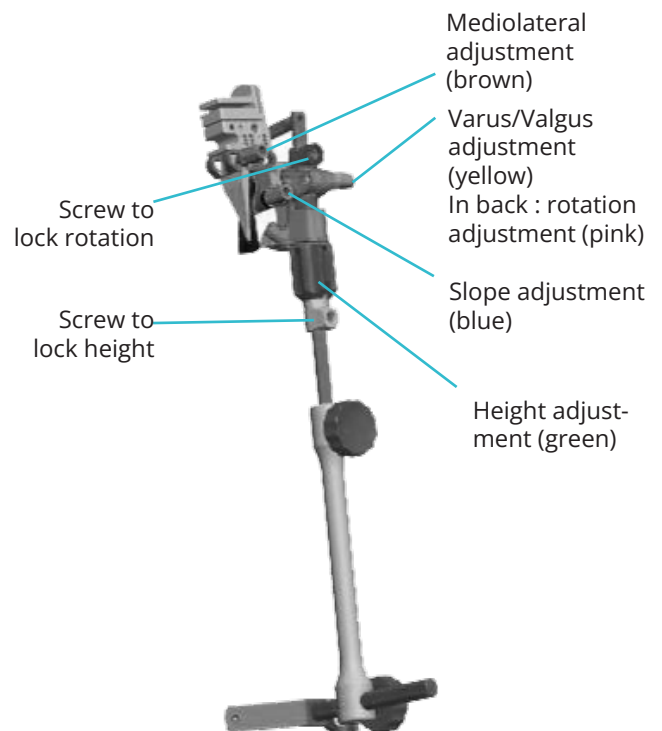

# 1 Extra-medullary tibial guide

## Placement of the Extra-medullary :

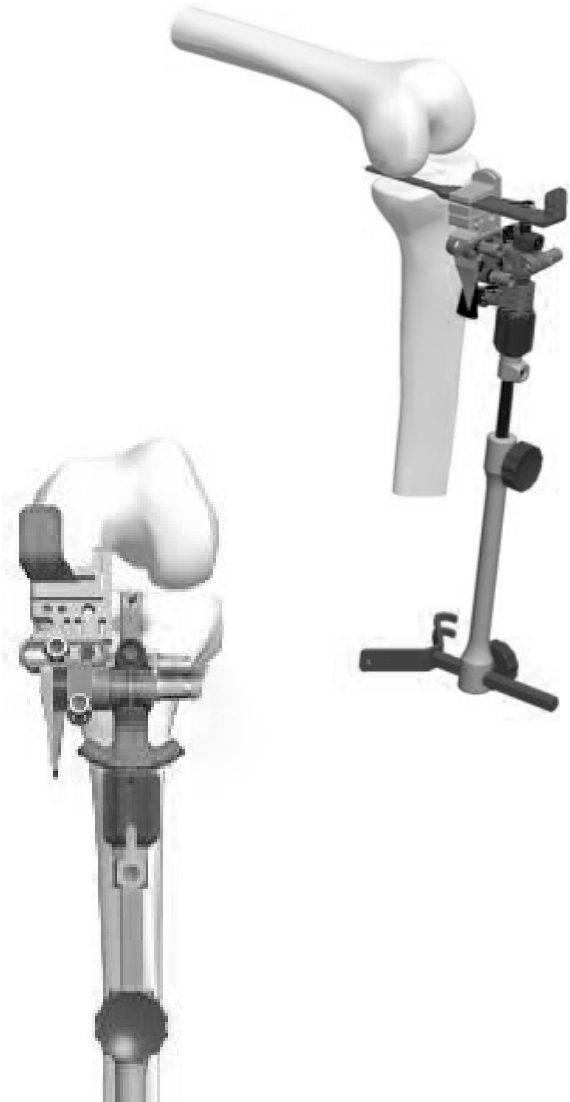

- Position the alignment frame and adjust it in the frontal and sagittal planes.
- Secure the entire construct using the Collared K-wire Ø4 Length 100 mm and the Pin Driver AO or Universal quick release adaptor for pin. The fixation area is located 0.5 cm below the anterior edge of the tibia and centred over the intercondylar eminence (medial side of tibial tuberosity). Reflect the patellar tendon and pierce through it if needed.
- Loosen the two locking screws and insert the Short or Long joint line gauge, making sure it rests on the anterior and posterior edges of the tibial plateau.
- Flexing the knee to 30° will reveal any wear-related laxity and make it easier to insert the gauge.
- Tighten the two locking screws, slope locking screw, mediolateral adjustment screw and rotation adjustment screw using the H5 Screwdriver.

### NOTE

Use the joint line gauge (short or long) that touches both the anterior and posterior edges without abutting against the joint capsule. Use the Curved joint line gauge for lateral UKA cases. Its curvature allows it to bend around the convexity of the joint surface.

---

# 1 Extra-medullary tibial guide

## Adjustments to the tibial resection guide:

- Remove the Joint line gauge and flex the knee 90°.
- The graduated scale showing the slope value (in blue color) is mobile. It must be positioned so the needle is over the 0° value. This corresponds to a 0° slope relative to the position of the gauge in the sagittal plane (resulting position when gauge rests on the anterior and posterior edges of the tibial plateau).
- Loosen the blue slope screw with the H5 Screwdriver. Set the needle to the desired angle (2° increments) and tighten the screw.
- Loosen the rotation locking screw and set the resection height to  $\pm 8$  mm using height adjustment screw (green knob). Re-tighten the rotation locking screw.

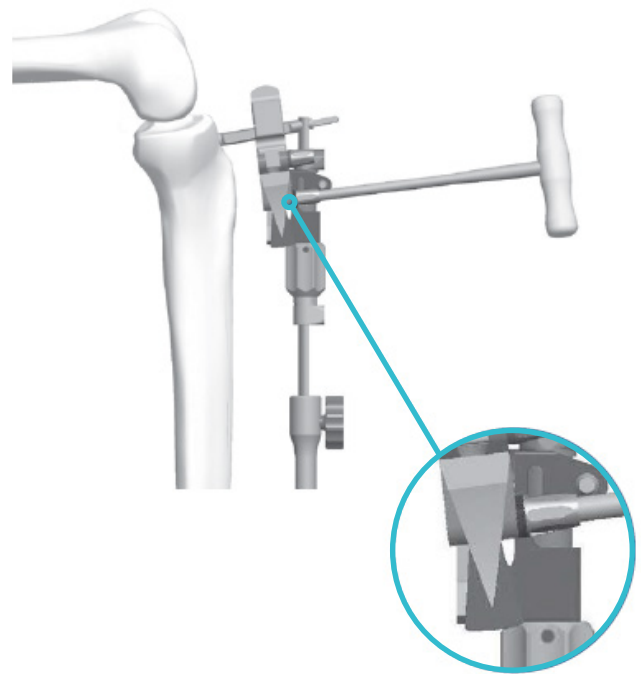

- Set the mediolateral position (brown knob) and rotation (pink knob) of the sagittal cut; use the Narrow resection gauge as needed to pinpoint the location.
- Lock the mediolateral position of the tibial resection guide.

# 1 Extra-medullary tibial guide

## Adjustments to the tibial resection guide:



- Verify the thickness of the bone cut with the Narrow resection gauge.
- If needed, the resection height can be further adjusted (green knob) after loosening only the rotation locking screw.
- Insert two Headless pins length 80 mm into the holes marked '0' using a surgical motorised hand-piece and Universal quick release adaptor for pin or Pin Driver AO.
- Insert a Headed pin length 70 mm (oblique axis) to stabilise the resection guide.

### NOTE

**A Femoral probe for unicompartamental tibial guide can be used to adjust the tibial resection height: slide the probe onto the resection guide until it touches the femoral component.**

## 2 Tibial resection

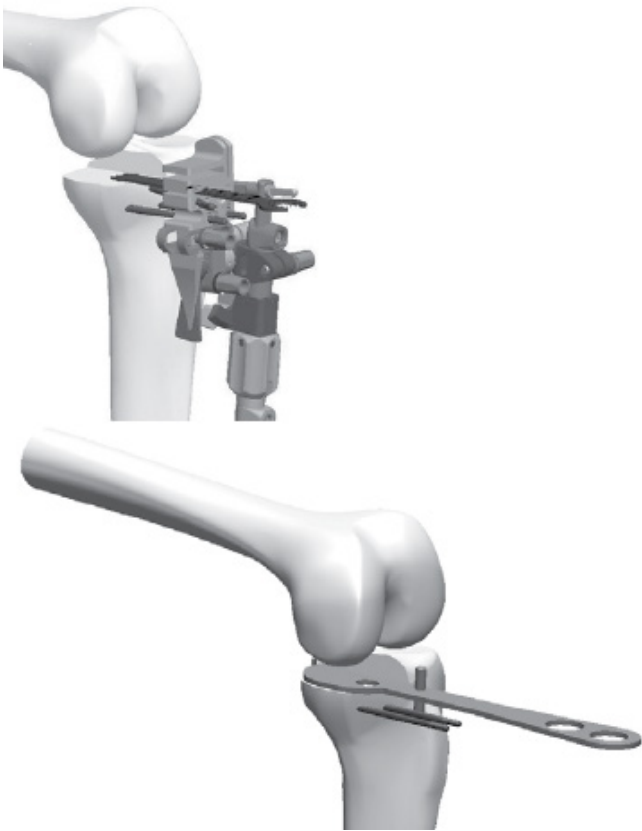

- Perform the tibial cut using the Narrow AMPLITUDE saw blade specific to the motorised hand-piece.
- Remove the headed pin with the Pin extractor.
- Remove the Collared K-wire Ø4 Length 100 mm with the motorised hand-piece. Loosen the adjustment thumb knobs.
- Slide the resection guide off the headless pins, but leave the pins in place in case recutting is necessary.
- Determine the size of the tibia using the Trial baseplate (size 1 to 7). The hook provides secure fixation on the posterior edge of the tibial plateau.

### NOTE

The Unicompartmental flat rasp can be used to refine the tibial cut.

### NOTE

If using a Cementless tibial tray with fixed insert, the peg position relative to the anterior side of the tibia can be marked with a scalpel.

- A UNI Trial Fixed Insert (Size 1 to 7 and Thickness 8 to 12 mm) can be used to check the tibial cut. During knee flexion, the anterior side of the trial baseplate must not lift off; if it does, the tibial slope is not sufficient.

### 3 Verification of flexion and extension gaps

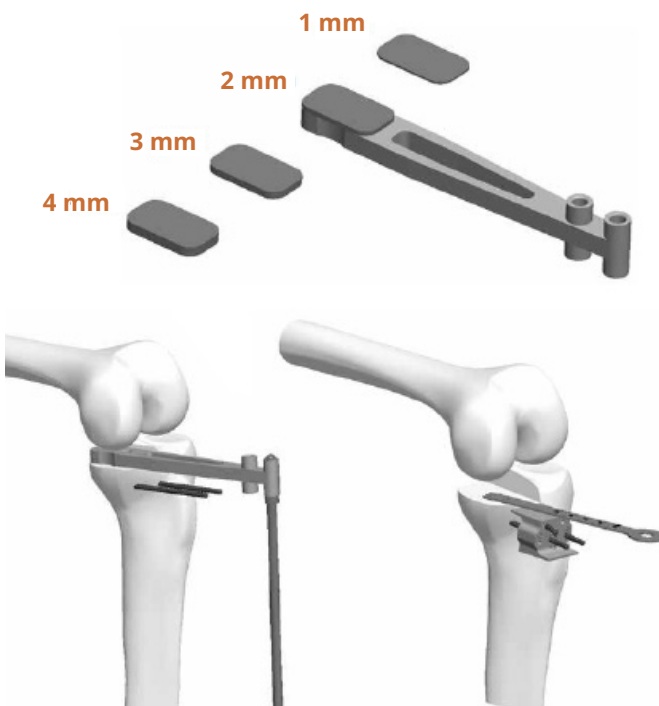

#### Verification of flexion gaps :

- Flex the knee.
- At this point, the gaps can be verified using the Spacer handle 8 mm that can be connected with the Extramedullary alignment rods.
- Wedges for spacer (thickness 1, 2, 3 or 4 mm) can be added to the 8 mm spacer to more precisely set the ligament tension and determine the height of the tibial insert.
- If the anterior side of the baseplate lifts off during joint testing (insufficient slope), the tibial cut can be redone while increasing the tibial slope by 2° or 4° with the Unicompartmental tibial resection guide.

#### NOTE

To increase the tibial slope by 2°, place the Unicompartmental tibial resection guide on the K-wires at '0' (the 'slope 2°' marking must be visible). If the resection height also needs to be increased, set the tibial resection guide on the K-wires at +2 or +4 mm. Make the cut by pushing the blade in the upper side of the guide until it stops. To increase the tibial slope by 4°, place the Unicompartmental tibial resection guide so the 'slope 4°' marking is visible.

#### Verification of extension gaps :

- Extend the knee.
- Use an electrocautery pen to mark the femur where the anterior edge of the tibial plateau is located when the knee is extended.
- Insert the Spacer handle 8 mm and the Wedge for spacer used when the knee was flexed.
- If the femoral component is significantly worn, 1 or 3 mm wedges can be used to fill the distal condylar defect; the wedge is placed between the condyle and spacer.
- Once the extension and flexion gaps are satisfactorily balanced, remove the two headless pins.



---

## 4 Femoral resections

### Distal cut in extension :

- If a wedge was used to determine the tibial insert height in the previous step, place it between the distal resection guide and tibial cut.
- If a wedge was used to make up for femoral wear in the previous step, place it between the distal resection guide and distal condyle.
- Extend the knee.
- Place the Distal resection guide (L.RM/LL or LM/RL) against the distal condyle and tibial cut.
- Check the guide position with the Extramedullary alignment rod.
- Check the guide position relative to the mark on the anterior edge of the tibial plateau with the knee extended.
- Insert two Headless pins length 80 mm using a surgical motorised hand-piece and Universal quick release adaptor for pin or Pin Driver AO.
- Make the distale femoral cut.
- Remove the two headless pins and the distal resection guide.

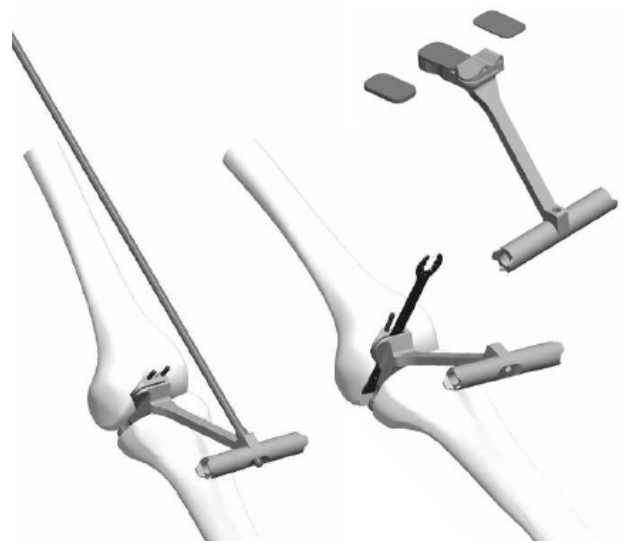

## 4 Femoral resections

### Placement of posterior resection and chamfer guide:

- Flex the knee to 90°.
- Select the Posterior femoral resection guide that matches the operated side (RM/LL or LM/RL). Use the H5 Screwdriver to place it on the Holding wrench for unicompartmental femoral cutting guide.
- Determine the best femoral component size using the 7 Posterior femoral resection guide templates (size 1 to 7) and the following to criteria:
  - Make sure there is no anterior overhang by setting the camber; the component must not project beyond the mark that represents the tibia's anterior edge, otherwise the patella could be impinged.
  - Make sure there is good medio-lateral coverage and the component is as centred as possible.
  - Ensure the component fully rests on the distal cut and the posterior condyle.
- Insert the Headless pins Ø 3.2 Length 55 mm using a surgical motorised hand-piece and Universal quick release adaptor for pin or Pin Driver AO.
- Make the posterior condylar cut (6 mm maximum) and then the chamfer cut.



#### NOTE

**A Spacer Thickness 6 mm for posterior femoral resection guide can be used to facilitate the positioning of the cutting guide: slide it between the tibial cut and Posterior femoral resection guide .**

## 5 Trial implants and joint testing

- Use the Unicompartmental femoral component holder to insert the UNI trial femoral component (the same size as the Posterior femoral resection guide that was used) into place, and then impact it using the Unicompartmental femoral component impactor.
- On the tibial cut, place the UNI Trial Fixed Insert for a FIXED tray (all-polyethylene or metal tibial tray)
- Test the stability of the femoral and tibial components.
- Make sure there is a laxity safety margin at approximately 30° knee flexion (takes into account under-correction requirement).



## 6 Femoral and tibial preparation



- Place the Drilling guide for unicompartmental femoral component peg of the same size as that of the femoral component onto UNI trial femoral component.
- Use the Drill for Unicompartmental Femoral Peg to make pilot holes for the anchoring pegs.
- Resect any posterior osteophytes with the Unicompartmental osteotome; this prevents impingement during hyperflexion.
- Put the appropriate-sized UNI trial tray into the knee.
- Set the Tibial fin punch into the slot on the plate, making sure to choose the appropriate side: RM/ LL or LM / RL.
- Impact it completely.
- Remove the trial femoral component.

## 7 Cementless tibial tray for fixed bearing insert



### Peg preparation:

- Screw the Guiding barrel for drill bit with stop Ø10 mm onto the UNI trial baseplate .
- Place the entire construct back on the tibial cut; hyperflexing the knee and externally rotating the tibia will make insertion easier.
- Prepare the peg hole by drilling with the Drill bit with stop Ø10 mm.

#### NOTE

If it is difficult to tighten and loosen the guiding barrel on the trial baseplate, use the Tibial stem wrench available in the instrumentation set.

### Placement of chosen cementless tibial implant without fixation screw:

No fixation screw is needed when using the cementless tibial tray for fixed insert:

- Impact the Cementless tibial tray (without the insert) using the Unicompartmental baseplate impactor.
- Put the PEEK cap into the hole on the top of the baseplate.
- Based on the thickness validated during the testing phase, select an insert of the same size as the baseplate. Introduce the insert from the posterior side of the baseplate. Slide in the posterior edge of the insert, making sure the attachment notches are completely clear. Impact the anterior edge of the insert with the Unicompartmental baseplate impactor.



#### NOTE

The PEEK cap is packed with the cementless tibial tray for fixed bearing insert; it can be used with or without a fixation screw.

#### NOTE

The PEEK cap, insert and tibial tray can be assembled on the back table.

## 7 Cementless tibial tray for fixed bearing insert

### Placement of chosen cementless tibial implant with fixation screw:

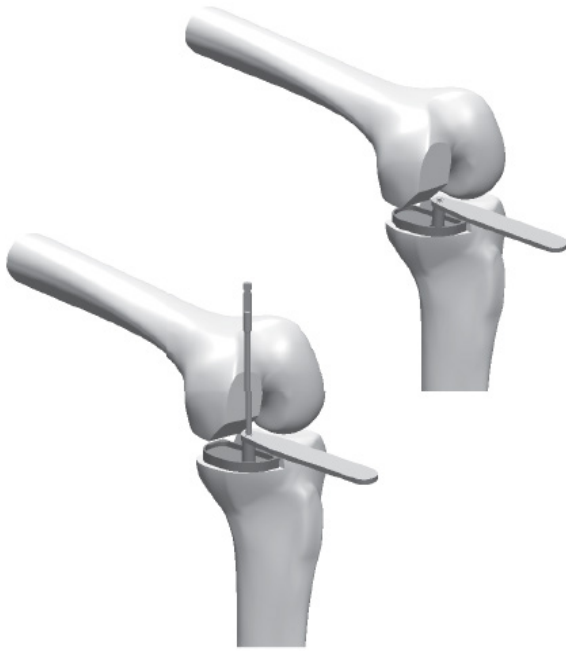

If fixation screw is needed with the cementless tibial tray for fixed insert (only)

- Put the Drill guide for drill bit D Ø 3,2 mm into place; the screw can be angled up to 18°.
- Drill a hole using the Long Drill bit Ø3.2 mm length 145 mm.

- Select a Ø6.5 mm fixation screw that matches the hole's depth; screws are available in lengths of 16 mm, 20 mm and up to 55 mm in 5-mm increments.
- Use the Screw holder Clamp to hold the screw and put it through the peg hole.
- Tighten the screw with the Retentive straight screwdriver H3.5 until the bottom of the screw head touches the tibial baseplate.
- Put the PEEK cap into the hole on the top of the baseplate.
- Based on the thickness validated during the testing phase, select the insert of the same size as the baseplate. Slide in the posterior edge of the insert, making sure the attachment notches are completely clear. Impact the anterior edge of the insert with the Unicompartmental baseplate impactor.

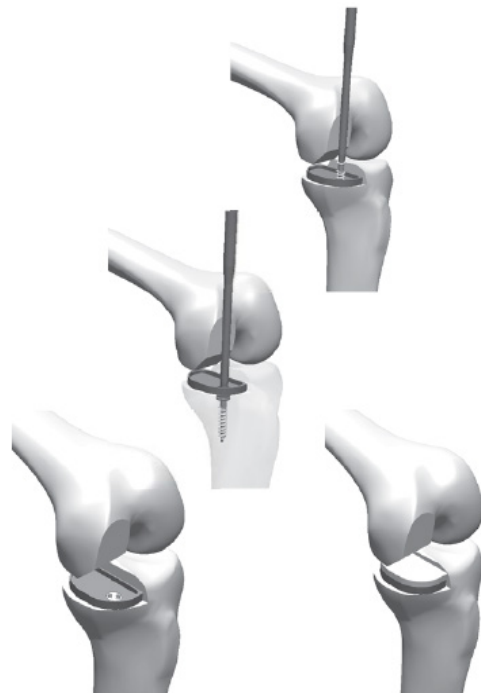

**NOTE**  
The PEEK cap is packed with the cementless tibial tray for fixed insert; it can be used with or without a fixation screw.

## 8 All-polyethylene tibial component cemented

- Impact the final all-polyethylene tibial component cemented of the same size and thickness as that validated during the testing phase with the Unicompartmental baseplate impactor.

### NOTE

Follow the instructions provided with the surgical cement.  
Please do not use cement with a cementless implant.



---

## 9 Femoral component



- Put the femoral component (cemented or cementless) in the Unicompartmental femoral component holder.
- Flex the knee 90° and impact the component.
- Finish impacting with the Unicompartmental femoral component impactor.

### NOTE

**If using a cemented femoral component, follow the instructions provided with the surgical cement.**

## Appendix A

### Unicompartmental tibial guide assembly

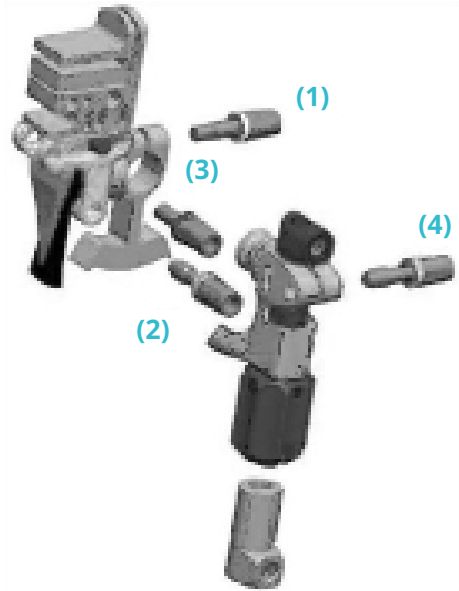

#### Medial left / Lateral right

- Fully loosen the yellow screw (1).
- Remove the tibial resection guide from its support.
- Flip the tibial resection guide 180° and secure it to its support (on the right), then put the yellow screw back into place (1).
- Loosen the blue screw (2) and put it back on the anterior side of the guide (accessible to surgeon).
- Loosen the brown screw (3) and put it back on the anterior side of the guide (accessible to surgeon).
- Loosen the pink screw (4) and put it back on the same side as the yellow screw (1).

#### Medial right / Lateral left

- Fully loosen the yellow screw (1).
- Remove the tibial resection guide from its support.
- Flip the tibial resection guide 180° and secure it to its support (on the left), then put the yellow screw back into place (1).
- Loosen the blue screw (2) and put it back on the anterior side of the guide (accessible to surgeon).
- Loosen the brown screw (3) and put it back on the anterior side of the guide (accessible to surgeon).
- Loosen the pink screw (4) and put it back on the same side as the yellow screw (1).

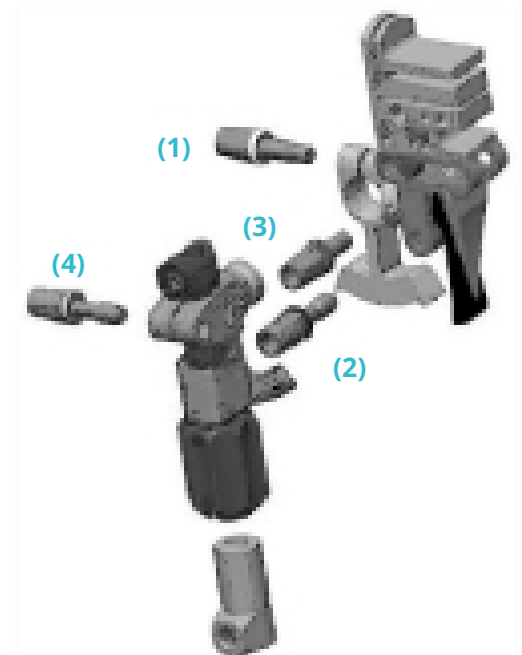

---

# Unicompartmental Knee System



**UNI SCORE- Cementless tibial tray for fixed-bearing insert**



**UNI SCORE All-poly Tibial Component Cemented**

## Extraction

- If the cementless UNI SCORE tibial tray with peg and fixation screw have to be revised:
  - Remove the femoral component using bone chisels.
  - Pry out the insert by placing an osteotome between the insert and base-plate.
  - Remove the PEEK stopper with forceps (e.g. Kocher forceps).
  - Loosen the screw using the H3.5 screwdriver with self-retaining tip.
  - Remove the tibial tray using bone chisels.
  
- If the femoral component needs to be removed, a slap-hammer can be assembled with the unicompartamental femoral component holder available upon request :
  - After making sure the femoral component is no longer anchored to the bone, remove the component.

---

# Instrumentation

- The UNI SCORE instrumentation for conventional surgery consists of two trays that have two layers each:
  - One set for tibial and femoral resection
  - One set for tibial/femoral preparation and trials
  
- In addition :
  - Sterile narrow saw blades

# Instrumentation

## Tibial and femoral resection set

2-02999147

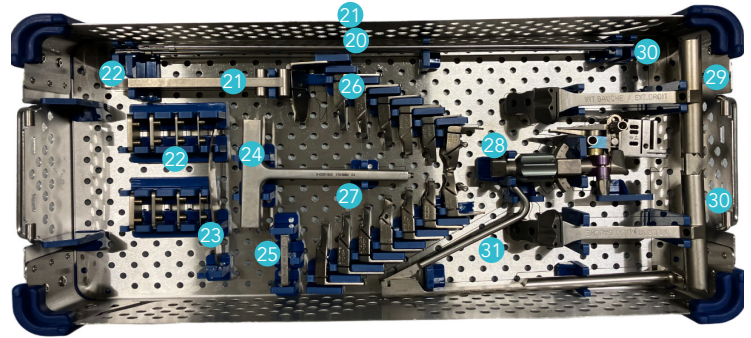
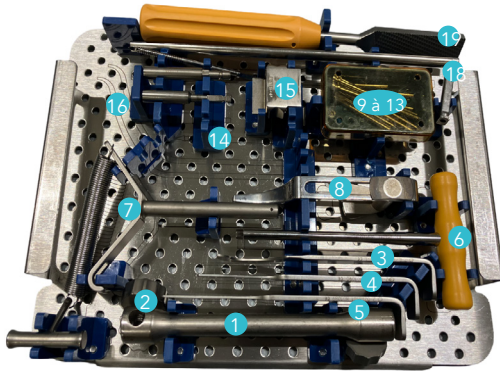

Rep	Name	Product No.	Qty
1	Extramedullary alignment column Ø8 mm	2-0118400	1
2	Wheel for extramedullary alignment column	2-0201800	2
3	Curved joint line gauge	2-0218503	1
4	Short joint line gauge	2-0218502	1
5	Long joint line gauge	2-0218501	1
6	H5 Screwdriver	2-0200800	1
7	Malleolar clamp	2-0201600	1
8	Femoral probe for unicompartimental tibial guide	2-0218700	1
9	Headed pin length 70 mm	2-0201302	3
10	Headless pin length 80 mm	2-0201400	3
11	Headed pin length 38 mm	2-0201304	2
12	Headed pin length 30 mm	2-0201301	1
13	Headless pin Ø 3.2 Length 55mm	2-0201401	3
14	Collared K-wire Ø4 Length 100mm	2-0218300	1
15	Unicompartimental tibial resection guide	2-0221300	1
16	Pin driver AO	2-0201200	1
17	Universal quick release adaptor for pin	2-0201100	1
18	Extrameduallary slide bar	2-0218200	1
19	Unicompartimental flat rasp	2-0221400	1
20	Extramedullary alignment rod	2-0200600	2
21	Spacer handle	2-0218800	1
22	Wedge thickness 1 mm for spacer	2-0218901	2
22	Wedge thickness 2 mm for spacer	2-0218902	2

# Instrumentation

## Tibial and femoral resection set

2-02999147

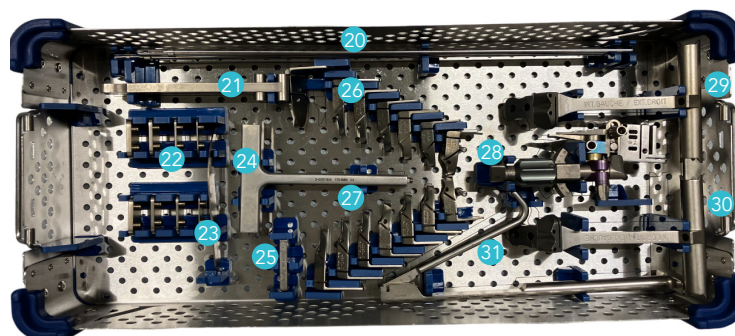
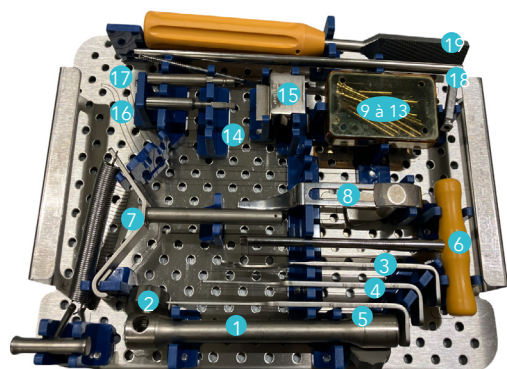

Rep	Name	Product No.	Qty
22	Wedge thickness 3 mm for spacer	2-0218903	2
22	Wedge thickness 4 mm for spacer	2-0218904	2
23	Narrow resection gauge	2-0218600	1
24	Holding wrench for unicompartamental femoral cutting guide	2-0221000	1
25	Spacer Thickness 6 mm for posterior femoral resection guide	2-0223100	1
26	Posterior femoral resection guide Size 1 R. MED/L. LAT.	2-0219201 to 2-0219207	7
27	Posterior femoral resection guide Size 1 L. MED/R. LAT.	2-0219101 to 2-0219107	7
28	Unicompartamental tibial guide	2-0218100	1
29	Distal resection guide L. MED / R. LAT.	2-0219001	1
30	Distal resection guide R. MED / L. LAT.	2-0219002	1
31	Pin extractor	2-0201500	1

# Instrumentation

## Tibial / Femoral preparation and trial set

2-02999147

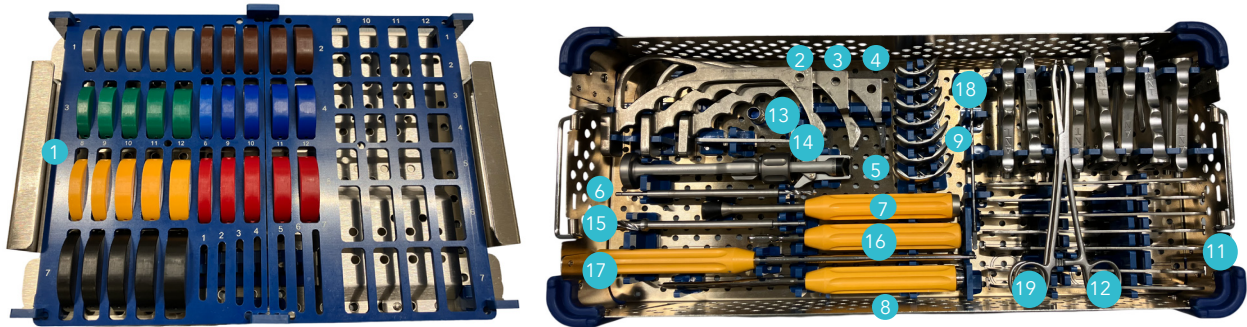

Rep	Name	Product No.	Qty
1	UNI Trial Fixed Insert Size 1 Thickness 8	2-0220111	1
1	UNI Trial Fixed Insert Size 1 Thickness 9	2-0220121	1
1	UNI Trial Fixed Insert Size 1 Thickness 10	2-0220131	1
1	UNI Trial Fixed Insert Size 1 Thickness 11	2-0220141	1
1	UNI Trial Fixed Insert Size 1 Thickness 12	2-0220151	1
1	UNI Trial Fixed Insert Size 2 Thickness 8	2-0220112	1
1	UNI Trial Fixed Insert Size 2 Thickness 9	2-0220122	1
1	UNI Trial Fixed Insert Size 2 Thickness 10	2-0220132	1
1	UNI Trial Fixed Insert Size 2 Thickness 11	2-0220142	1
1	UNI Trial Fixed Insert Size 2 Thickness 12	2-0220152	1
1	UNI Trial Fixed Insert Size 3 Thickness 8	2-0220113	1
1	UNI Trial Fixed Insert Size 3 Thickness 9	2-0220123	1
1	UNI Trial Fixed Insert Size 3 Thickness 10	2-0220133	1
1	UNI Trial Fixed Insert Size 3 Thickness 11	2-0220143	1
1	UNI Trial Fixed Insert Size 3 Thickness 12	2-0220153	1
1	UNI Trial Fixed Insert Size 4 Thickness 8	2-0220114	1
1	UNI Trial Fixed Insert Size 4 Thickness 9	2-0220124	1
1	UNI Trial Fixed Insert Size 4 Thickness 10	2-0220134	1
1	UNI Trial Fixed Insert Size 4 Thickness 11	2-0220144	1
1	UNI Trial Fixed Insert Size 4 Thickness 12	2-0220154	1
1	UNI Trial Fixed Insert Size 5 Thickness 8	2-0220115	1
1	UNI Trial Fixed Insert Size 5 Thickness 9	2-0220125	1
1	UNI Trial Fixed Insert Size 5 Thickness 10	2-0220135	1
1	UNI Trial Fixed Insert Size 5 Thickness 11	2-0220145	1
1	UNI Trial Fixed Insert Size 5 Thickness 12	2-0220155	1

# Instrumentation

## Tibial / Femoral preparation and trial set

2-02999147

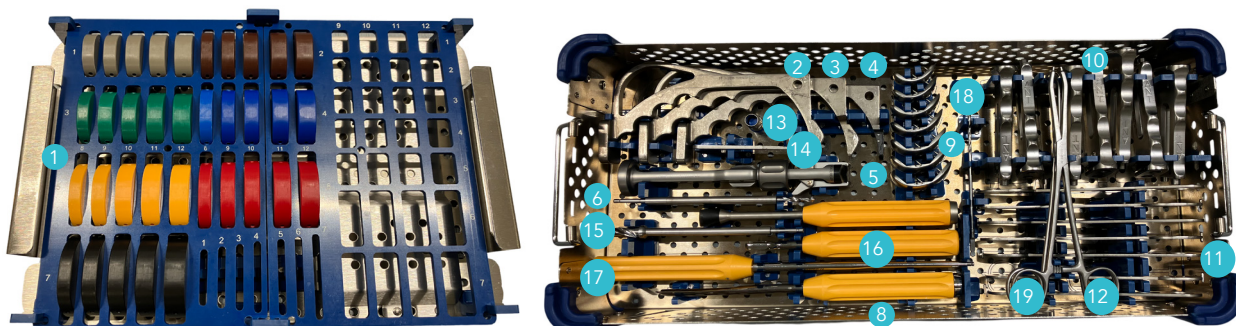

Rep	Name	Product No.	Qty
1	UNI Trial Fixed Insert Size 6 Thickness 8	2-0220116	1
1	UNI Trial Fixed Insert Size 6 Thickness 9	2-0220126	1
1	UNI Trial Fixed Insert Size 6 Thickness 10	2-0220136	1
1	UNI Trial Fixed Insert Size 6 Thickness 11	2-0220146	1
1	UNI Trial Fixed Insert Size 6 Thickness 12	2-0220156	1
1	UNI Trial Fixed Insert Size 7 Thickness 8	2-0220117	1
1	UNI Trial Fixed Insert Size 7 Thickness 9	2-0220127	1
1	UNI Trial Fixed Insert Size 7 Thickness 10	2-0220137	1
1	UNI Trial Fixed Insert Size 7 Thickness 11	2-0220147	1
1	UNI Trial Fixed Insert Size 7 Thickness 12	2-0220157	1
2	Tibial fin punch R.MED / L. LAT	2-0219400	1
3	Tibial fin punch L. MED / R. LAT	2-0219500	1
4	Unicompartmental baseplate impactor	2-0219600	1
5	Unicompartmental femoral component holder	2-0220500	1
6	Drill for Unicompartmental Femoral Peg	2-0218000	1
7	Unicompartmental femoral component impactor	2-0220400	1
8	Unicompartmental osteotome	2-0221500	1
9	UNI trial femoral component – Size 1 to Size 7	2-0219701 to 2-0219707	7



# Instrumentation

## Tibial / Femoral preparation and trial set

2-02999147

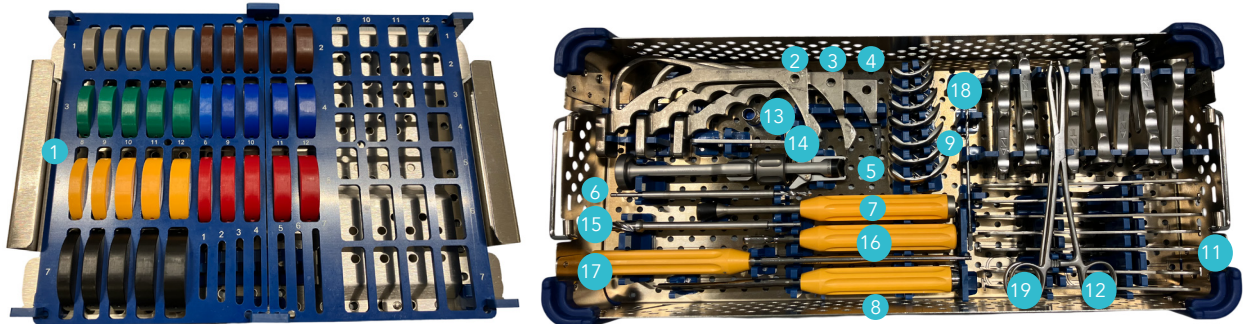

Rep	Name	Product No.	Qty
10	Drilling guide for unicompartmental femoral component peg – Size 1 to 7	2-0219801 to 2-0219807	7
11	Trial baseplate – Size 1 to 7	2-0230401 to 2-0230407	7
12	Holding clamp	2-0220300	1
13	Guiding barrel for stop drill bit Ø10 mm	2-0230000	1
14	Drill guide for drill bit D 3,2	2-0230200	1
15	Drill bit with stop Ø10 mm	2-0230100	1
16	Tibial stem Wrench	2-0205500	1
17	Retentive straight screwdriver H3.5	2-0230500	1
18	Long Drill bit Ø3.2 length 145 mm	2-0102400	1
19	Screw holder Clamp	2-0102800	1

---

# Instrumentation

## Narrow saw blades

SYNTHES AO / SODEM narrow saw blade  
Sterile Product No. 2-0228101

---

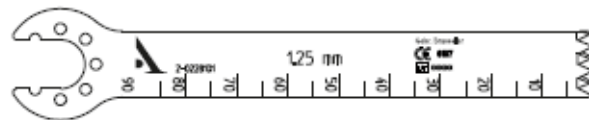

STRYKER narrow saw blade  
Sterile Product No.  
2-0228102

---

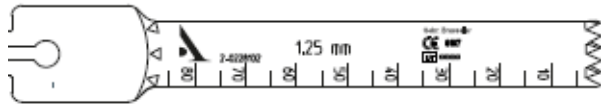

ZIMMER / HALL / LINVATEC narrow  
blade  
Sterile Product No. 2-0228103

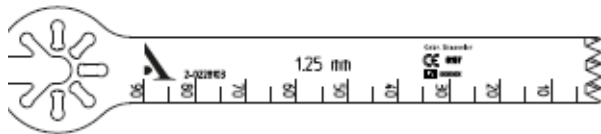

---

# NOTES

---

---

---

---

---

---

---

---

---

---

---



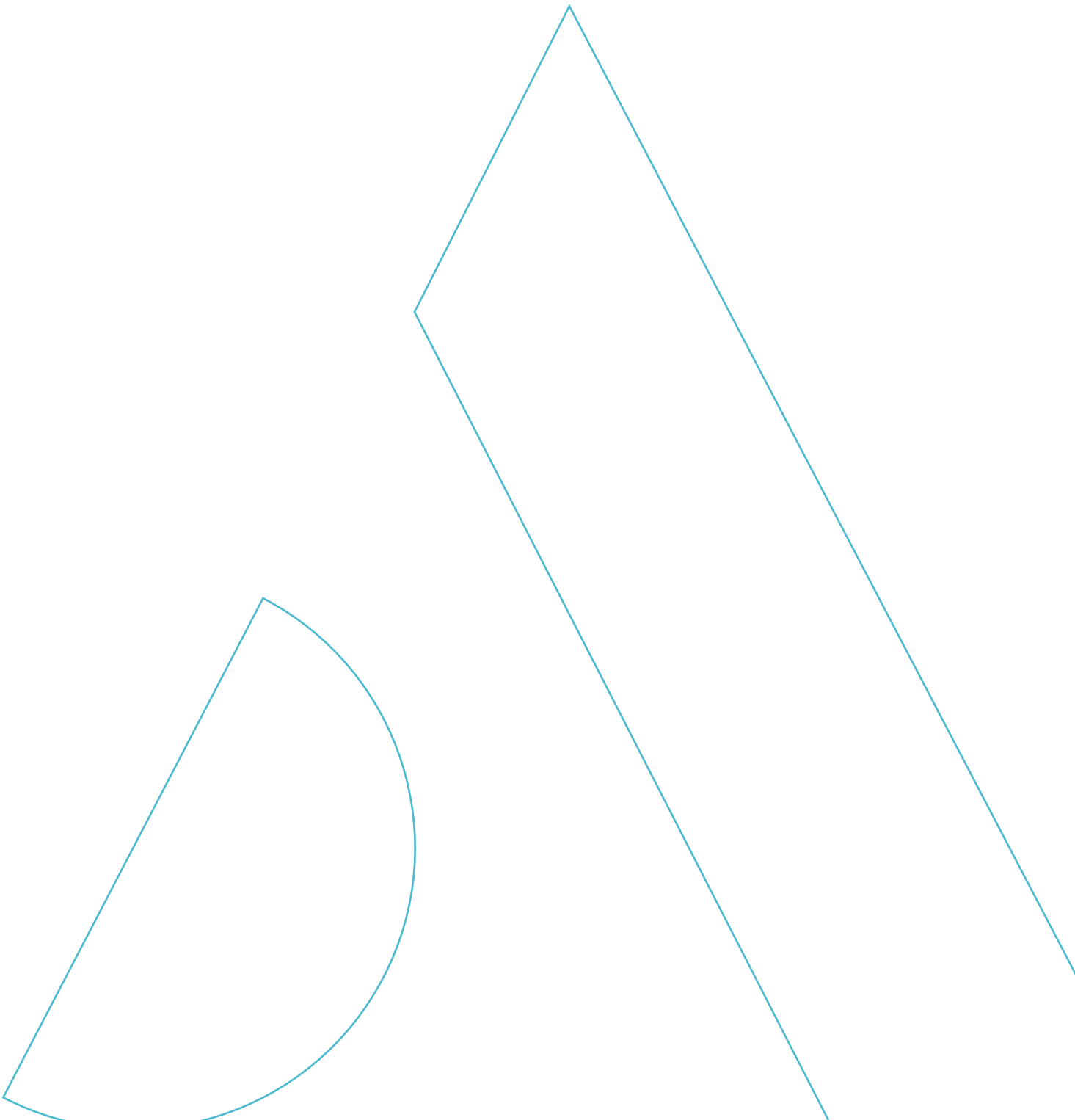



**Service Clients – France :**

Porte du Grand Lyon,  
01700 Neyron – France  
Tél. : **+33 (0)4 37 85 19 19**  
Fax : +33 (0)4 37 85 19 18  
E-mail : [amplitude@amplitude-ortho.com](mailto:amplitude@amplitude-ortho.com)

**Customer Service – Export :**

11, cours Jacques Offenbach,  
ZA Mozart 2,  
26000 Valence – France  
Tél. : **+33 (0)4 75 41 87 41**  
Fax : +33 (0)4 75 41 87 42

[www.amplitude-ortho.com](http://www.amplitude-ortho.com)



<https://eifu.amplitude-ortho.com>

Reference : TO.G.016/EN/C